

AJ75/LG411R75MA

SOTR

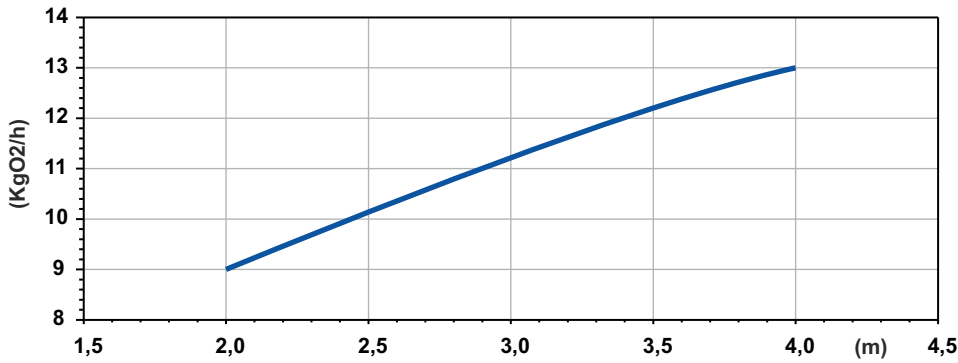

Potenza Assorbita - Absorbed Power P1
 Puissance Absorbée - Leistungsaufnahme P1
 Potencia Absorbida - Поглощенная мощность P1

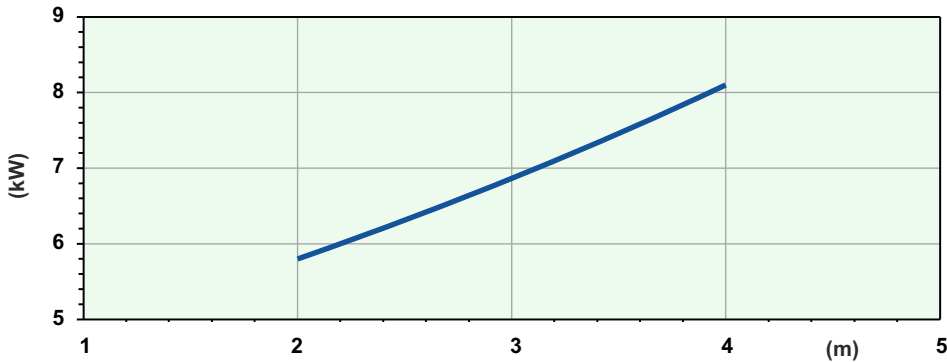

Battente idraulico - Hydraulic head - Charge hydraulique - Hydraulischen Belastung
 Cabezal hidráulico - Аспирированный воздух

Code	5006589
Type	AJ75/LG411R75MA
Suction (mm)	DN80
Free passage (mm)	30x35
Immersion depth (m)	2-4
Motor type	M411T-8,5-400/50YY-IE3
Power supply	3ph 400/690V-50Hz
MOTOR Rotation speed R.P.M.	1436
Rated power P2 (kW)	8,5
Rated current I (A)	16,2
Starting current Is (A)	95,6
Weight (Kg)	210
Cable	H07RN/F 12G2.5
SOTR OBTAINED FOLLOWING STANDARD UNI EN 12255-15:2004	

Dimensioni - Dimensions - Dimensions - Abmessungen - Dimensiones - Габариты (mm)

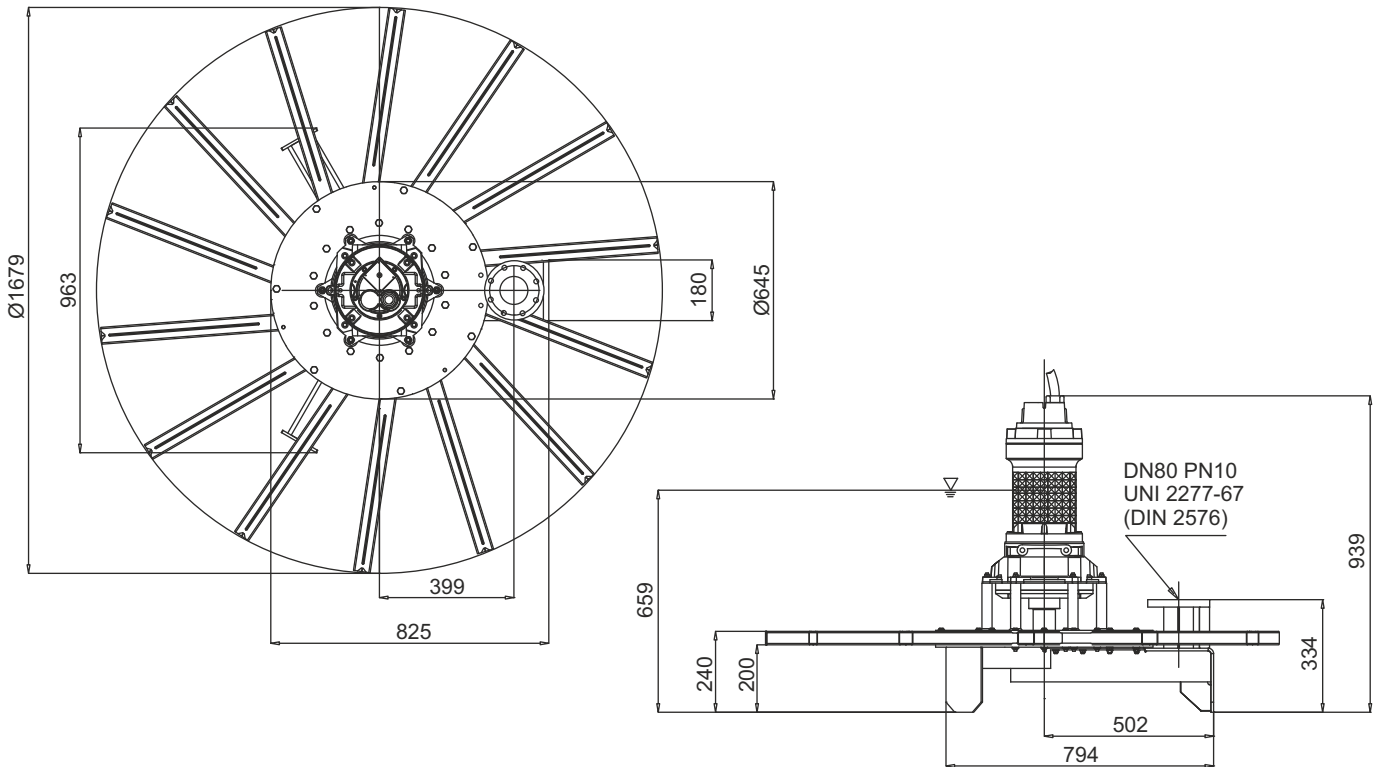

LIVELLO MINIMO DI SOMMERGIBILITÀ - MINIMUM SUBMERSIBLE LEVEL - NIVEAU MINIMUM D'IMMERSION
 MINDESTWASSERSTAND - NIVEL SUMERGIBLE MÍNIMO - МИНИМАЛЬНАЯ ГЛУБИНА ПОГРУЖЕНИЯ